



Georg-August-Universität
Göttingen

Faculty of Economic Sciences
Production and Logistics

Five Years

Chair of Production und Logistics

Prof. Dr. Jutta Geldermann

2006 - 2011



Georg-August-Universität Göttingen

Faculty of Economic Sciences

Chair of Production and Logistics

Prof. Dr. Jutta Geldermann

Address: Platz der Göttinger Sieben 3
D - 37073 Göttingen, Germany

Tel.: +49 (0)551 / 39-7257

Fax: +49 (0)551 / 39-9343

Email: produktion@wiwi.uni-goettingen.de

Homepage: www.produktion.uni-goettingen.de



Contents

Preface.....	5
1 Teaching.....	7
1.1 Bachelor Studies	7
1.1.1 Production and Logistics.....	7
1.1.2 Production Management	7
1.1.3 Logistics Management.....	8
1.1.4 Seminar: Specific Problems in Production and Logistics Management	8
1.2 Master Studies	8
1.2.1 Corporate Planning.....	8
1.2.2 Logistics and Supply Chain Management.....	9
1.2.3 Industrial Facility and Energy Management.....	9
1.2.4 Production and Environment	9
1.2.5 Seminar: Current Approaches to Production and Logistics.....	10
1.3 Final Year Theses.....	10
1.4 Guest Lecture	10
2 Publications.....	11
2.1 Books.....	11
2.2 Articles in Professional Journals	13
2.3 Book Chapters.....	15
2.4 Conference Papers	19
2.5 Research Report.....	23
2.6 Publications without Review-Process	23
3 Research Projects.....	25
3.1 Joint Research Project: “Sustainable Use of Bioenergy: Bridging Climate Protection, Nature Conservation and Society”	26
3.2 International Collaboration in Research and Teaching between the University of Göttingen and the University of Concepción (Chile): “Sustainable Use of Energy-Generated Biomass between the Contradictory Contexts of Climate, Landscape and Society”	30
3.3 Costs and Potentials of Greenhouse Gas Abatement in Lower Saxony.....	31
3.4 Accompanying Economic Research for “e-Home”	33
3.5 Life-Cycle Assessment of Biogas Plants in Consideration of the Regional Context in Lower Saxony (Germany).....	34

3.6	PhD Program “Biodiversity and Society”: Development of Indicators to Assess the Potential Impact of Road Transport on Biodiversity	36
3.7	Collaboration and Scientific Exchange: “Optimization and its Applications in Learning and Industry“	38
3.8	Leasing of Chemicals as a Model for Sustainable Development with Test Procedures and Quality Criteria on the Basis of Pilot Projects in Germany	40
3.9	Analysis of Life-Cycle-Cost Business Models.....	42
3.10	Research Training Group (RTG 1703) “Resource Efficiency in Corporate Networks - Methods for Enterprise and Corporate-Level Planning to Utilize Renewable Resources”	43
3.11	IT-for-Green: Next-Generation Environmental Management Information Systems	44
3.12	Socio-Economic Analysis (SEA) for the Registration and Restriction according to REACH: Assessment of the Abatement Costs of Chemicals– ex ante und ex post	46
4	Doctorates.....	47
4.1	Current Doctorates	47
4.2	Completed Doctorates.....	48
5	Team	49

Preface

The Göttingen Research Campus provides an inspiring environment for scientific research. The history of Göttingen University, founded in 1737, has to this day been characterized by scholarly pragmatism and a grounding in reality as well as a keen awareness for science's social responsibilities. Today, it is characterized by vivid intellectual exchange across and beyond conventional boundaries. The University of Göttingen has been promoted in the first program phase of the Excellence Initiative of the German Federal and State Governments. In worldwide rankings, our University is ranked among the best in Germany (Times Higher Education Ranking: 1st, Shanghai Ranking: 4th in Germany). According to the New York Times, the Faculty of Economic Sciences is among the top six German Business Schools most frequently selected by global employers.

This Five-Year Report provides an overview of the activities of the Chair of Production and Logistics at the Georg-August-University of Göttingen. On December 14th, 2006, I was appointed as a full professor in Göttingen after finishing my studies in Karlsruhe and Dublin and after my dissertation and habilitation were completed in Karlsruhe.

The interdisciplinary team at the Chair of Production and Logistics has grown steadily and now includes the disciplines of business administration, industrial engineering, business informatics, geocology, forest sciences, and mathematics.

The focus of our research activities is the cost-effective and resource-efficient design of production and logistics systems. We apply methods of operations research that are associated with production planning and process engineering. Multi-criteria decision support is a suitable approach for taking the three dimensions of sustainability - ecology, economy and social-consciousness - into account when comparing alternative production or logistics processes and preparing for investment decisions.

We place special emphasis on research questions concerning the sustainable use of bioenergy. The task of our first large research project, which has recently been extended by two years, is the optimization of production and logistics planning for bioenergy villages with district heating and a multi-criteria evaluation.

Together with my colleagues from the Faculties of Economic Science, Forestry Science, Agricultural Sciences, and Informatics and Mathematics at the University of Göttingen, we will establish the Research Training Group (RTG) 1703 "Resource Efficiency in Corporate Networks - Methods for Enterprise and Corporate-Level Planning to Utilize Renewable Resources" in April 2012. It has been funded by the German Research Foundation (Deutsche Forschungsgemeinschaft, DFG) until 2016.

Twelve PhD students will develop new planning approaches for the industrial utilization of renewable resources, with the comprehensive aim of cascade utilization - the multiple utilizations of a raw material before its conversion into energy. As a practical example, we investigate wood and wood materials used in the manufacturing and processing industries. The designated methods for improving resource efficiency will support decision-making and enable the operational control of production processes - a relevant issue that currently affects many companies. We are open to collaborating with interested companies!

Based on our research projects, we have the opportunity to incorporate those experiences into our teaching activities at the university. The Chair of Production and Logistics offers lectures and courses for the 3,000 students currently enrolled in the Bachelor's and Master's programs of the Faculty of Economic Sciences. The curriculum is primarily configured for students studying for a Bachelor's degree in business administration, business informatics, and economics as well as students studying for a Master's degree in business management, marketing and distribution management, business informatics, and business and human resource education.

Prof. Dr. Jutta Geldermann

1 Teaching

Our curriculum is directed primarily towards students in the Bachelor's programs in Business Studies, Business Information Systems, Business and Human Resource Education, and Economics and the Master's programs in Management, Marketing and Channel Management, and Business Information Systems. Regular meetings are held with all Ph.D. students.

1.1 Bachelor Studies

1.1.1 Production and Logistics

This compulsory course within the Bachelor program in Business Administration aims to provide students with an overview of company production processes and the close connection between production and logistics. Students will become familiar with the design of business processes and the efficient use of appropriate planning models.

- Production and cost theory
- Production planning using linear optimization
- Allocation planning / logistics of procurement
- Logistics of production
- Logistics of distribution
- Process simulation and visualization in production and logistics

1.1.2 Production Management

In this elective lecture and practicum, participants learn about the different applications of selected methods of operations research on issues of strategic, tactical and operational production management for various types of production processes. Students will learn about different production management methods in the following areas:

- Production processes
- Batch size planning
- Resource allocation planning
- Project planning
- Sequence planning
- Capacity planning

1.1.3 Logistics Management

This elective course utilizes lectures and exercises to introduce the foundations of logistics and logistics management within and between industrial enterprises. The primary focus in each area is model-based decision support, where methods from operations research can be applied.

- Introduction to logistics management
- Layout planning
- Transport and route scheduling
- Queue theory
- Storing and commissioning

1.1.4 Seminar: Specific Problems in Production and Logistics Management

Students are expected to explore current topics in production management and present their results during a block course. The main focuses of the seminar are the independent study of selected production and logistic processes and students' familiarization with the prevalent methods of operations research. Students practice the methodical treatment, presentation, and discussion of scientific problems and findings.

1.2 Master Studies

1.2.1 Corporate Planning

This lecture is required for the Master's degree in Management and optional for the other Master program studies at our faculty. Its focus is the application of methods of operation research to issues of strategic, tactical, ecological and operational business planning in an industrial company. Students will become familiar with decision support methods for typical decision-making problems in corporate planning.

- Remits of industrial production
- Location factors and planning
- Strategic corporate planning
- Transport and logistics

1.2.2 Logistics and Supply Chain Management

This elective course aims to provide students with an understanding of structural and logistical problems in and between producing companies. Quantitative models are presented. In addition, students learn to utilize various methods of operations research with regard to the strategic and operative management of logistics as well as ecological aspects.

- Introduction to logistical problems of supply chain management
- Location selection
- Transport scheduling
- Supply chain management
- Dynamic storing
- Mobility management

1.2.3 Industrial Facility and Energy Management

In this elective course, students become familiar with the relationship between planning and operating an industrial facility. Methods for estimating costs and investments as well as different capacity-planning approaches from operations research are presented. Another main focus is production planning in power-supplying industries.

- Introduction to industrial facility management
- Methods of estimating costs and investments of plants and equipment
- Facility and capacity planning
- Facility maintenance and waste management
- Introduction to energy management
- Energy efficiency

1.2.4 Production and Environment

Topics in this lecture include material-flow management on different operational levels. The focus of interest is the cost and environmentally efficient design of measures for the prevention, reduction and recycling of waste materials and the disposal of waste. Methods of operations research are applied. An additional focus is the trade of emission certificates. Case studies from different industrial sectors are presented.

- Introduction to material-flow management
- Environmental controlling and management
- Life-cycle assessment
- Techno-economic assessment of environmental protection measures
- Energy- and material-flow planning and control
- Methods of multi-criteria decision-making and optimization of energy and material flows
- Comprehensive approaches to corporate planning
- Trading of emission certificates

1.2.5 Seminar: Current Approaches to Production and Logistics

The participants in this seminar independently discuss current issues from the production and logistics sectors. Current literature regarding problem analysis in selected manufacturing and logistics processes is analyzed. The results of the final paper are presented and discussed in a block course. In this exercise, students formulate and present scientific questions. They become familiar with the requirements associated with presentations and discussions.

1.3 Final Year Theses

Due to the new structure of Bachelor and Master Studies, the former Diploma thesis was phased out in 2011. In the past five years, we have supervised 120 Diploma theses, 138 Bachelor theses and 49 Master theses on current topics in production and logistics. The actual topics are developed in relation to our research projects and industry contacts.

Teaching and research can only be current if they are developed in close relation to the practice of business. Therefore, we are eager to cooperate on topical questions with companies in Lower Saxony, Germany and worldwide. Internships related to Bachelor's and Master's theses are ideal both for students and companies.

1.4 Guest Lecture

As part of the lecture series "Business Management and Practice", which is organized by the major field of study Management, guest lectures have been held regularly since 2007. Esteemed individuals from renowned companies provide insights into their daily business and strategic challenges. The Chair of Information Management, the Chair of Controlling and Management, the Chair of Organization and the Chair of Production and Logistics jointly organize these events. We are open to new suggestions!

2 Publications

2.1 Books

2011

Lauven, L.P. *Evaluation of the Economic Perspectives of the Production of Synthetic Hydrocarbons in Germany.* Cuvillier Verlag, Göttingen

Wongsak, S. *Development of a decision support system for the logistics planning for agricultural products in Thailand.* Cuvillier Verlag, Göttingen

2010

Joas, R.; Geldermann, J.; Hesse, M.; Daub, A.; Raab, C. *Chemikalienleasing als Modell zur nachhaltigen Entwicklung mit Prüfprozeduren und Qualitätskriterien anhand von Pilotprojekten in Deutschland.* Umweltbundesamt, Dessau

Körner, M.-C.; Geldermann, J.; Schöbel, A. *Erträge, Diagramme und Algorithmen - Operations Research in der Praxis.* Shaker, Aachen

2009

Geldermann, J.; Lauven, L.-P. *Einsatz von OR-Methoden zur Entscheidungsunterstützung.* Shaker, Aachen

2008

Daub, A.; Buscher, U.; Bloech, J.; Bogaschewsky, R.; Götze, U.; Roland, F. *Einführung in die Produktion.* Springer Verlag, Heidelberg

Buscher, U.; Daub, A.; Götze, U.; Mikus, B.; Roland, F. *Produktion und Logistik: Einführung mit Fallbeispielen.* GUC-Verlag, Chemnitz

2007

Geldermann, J.; Treitz, M.; Schollenberger, H.; Ludwig, J.; Rentz, O. *Integrated Process Design for the Inter-Company Plant Layout Planning of Dynamic Mass Flow Networks*. Universitätsverlag, Karlsruhe

2006**Habilitation**

Geldermann, J. *Mehrzielentscheidungen in der industriellen Produktion*. Universitätsverlag, Karlsruhe

1999**Dissertation**

Geldermann, J. *Entwicklung eines multikriteriellen Entscheidungsunterstützungssystems zur integrierten Technikbewertung*. In: Fortschrittsberichte VDI, Vol. 16 (Technik und Wirtschaft), VDI Verlag, Düsseldorf

2.2 Articles in Professional Journals

2011

Geldermann, J.; Schöbel, A. *On the similarities of some MCDA methods.* Journal of Multi-Criteria Decision Analysis, Volume 18, Issue 3-4, pp. 219–230

Geldermann, J.; Bertsch, V.; Gering, F. *Risikomanagement und Mehrzielentscheidungsunterstützung unter Unsicherheit am Beispiel der Planung effizienter Notfallmaßnahmen nach kerntechnischen Störfällen.* Der Betriebswirt, Vol. 1, Gernsbach

2010

Zhang, K.; Cang, P.; Geldermann, J. *Application of Macbeth and Promethee in Waste Recycling System Evaluation.* Journal of Donghua University, Natural Science Journal of Donghua University (Natural Science), Vol. 36, No. 6, pp. 697-702

Geldermann, J.; Treitz, M.; Rentz, O. *Technique assessment for eco-industrial parks in China.* World Review of Science, Technology and Sustainable Development, Vol. 8 (1), pp. 47-61

Oberschmidt, J.; Geldermann, J.; Ludwig, J.; Schmehl, M. *Modified PROMETHEE approach to assessing energy technologies.* International Journal of Energy Sector Management Vol. 4 (2), pp. 183 - 212

Schmidt, N.-H.; Schmehl, M.; Thies, F.; Kolbe, L.M.; Geldermann, J. *Ökobilanzierung in der IT. Distributionsformen der Musikindustrie im Vergleich.* HMD - Praxis der Wirtschaftsinformatik, Vol. 274, pp. 65-73

2009

Geldermann, J.; Bertsch, V.; Treitz, M.; French, S.; Papamichail, K.N.; Hämäläinen, R.P. *Multi-criteria Decision Support and Evaluation of Strategies for Nuclear Remediation Management.* OMEGA - International Journal of Management Science Vol. 37 (1), pp. 238-251

Ludwig, J.; Treitz, M.; Rentz, O.; Geldermann, J. *Production planning by pinch analysis for biomass use in dynamic and seasonal markets.* International Journal of Production Research Vol. 47 (8), pp. 2079-2090

2008

- Bertsch, V.; Geldermann, J.: *Preference Elicitation and Sensitivity Analysis in Multi-Criteria Group Decision Support for Industrial Risk and Emergency Management*. International Journal of Emergency Management Vol. 5 (1/2), pp. 7-24
- Geldermann, J.; Merz, M.; Bertsch, V.; Hiete, M.; Rentz, O.; Seifert, I.; Thieken, A.H.; Borst, D.; Werner, U. *The reference installation approach for estimation of industrial assets at risk*. European Journal of Industrial Engineering, Vol. 2 (1), pp. 73-93
- Schollenberger, H.; Treitz, M; Geldermann, J. *Adapting the European Approach of Best Available Techniques: Case Studies from Chile and China*. Journal of Cleaner Production, Vol. 16 (17), pp. 1856-1864
- Geldermann, J.; Treitz, M. *Quantifying Eco-Efficiency with Multi-Criteria Analysis*. Research Paper der Georg-August-Universität Göttingen, Wirtschaftswissenschaftliche Fakultät, Schwerpunkt Unternehmensführung, Göttingen
- Schmehl, M.; Müssig, J.; Schönfeld, U.; von Buttlar, H.-B. *Life Cycle Assessment on a Bus Body Component Based on Hemp Fiber and PTP[®]*; Journal of polymers and the environment, Vol. 16 (1), pp. 51-60

2007

- Bertsch, V.; Treitz, M.; Geldermann, J.; Rentz, O. *Sensitivity Analyses in Multi-Attribute Decision Support for Off-Site Nuclear Emergency and Recovery Management*. International Journal of Energy Sector Management, Vol. 1 (4), pp. 342-365
- Geldermann, J.; Treitz, M.; Rentz, O. *Towards Sustainable Production Networks.*; International Journal of Production Research (IJPR) - Special Issue on Sustainable Production, Vol. 45 (18), pp. 4207-4224
- Geldermann, J.; Ludwig, J. *Some thoughts on weighting in participatory decision making and e-democracy*. Int. J. Technology, Policy and Management, Vol. 7 (2), pp. 178-189

Geldermann, J.; Treitz, M.;
Schollenberger, H.; Rentz, O.;
Huppel, G.; van Oers, L.;
France, C.; Nebel, B.; Clift, R.;
Lipkova, A.; Sietta, S.;
Desideri, U.; May, T.

An integrated scenario analysis for the metal coating sector in Europe. Technological Forecasting and Social Change, Vol. 74 (8), pp. 1482-1507

2006

Bertsch, V.; Geldermann, J.;
Rentz, O.; Raskob, W.

Multi-Criteria Decision Support and Stakeholder Involvement in Emergency Management. International Journal of Emergency Management, Vol 3 (2/3), pp. 114-130

Geldermann, J.; Treitz, M.;
Schollenberger, H.; Rentz, O.

Evaluation of VOC recovery strategies: Multi Objective Pinch Analysis (MOPA) for the evaluation of VOC recovery strategies. OR Spectrum - Special Issue on Product Recovery, Vol. 28 (1), pp.3-20

Geldermann, J.; Treitz, M.;
Rentz, O.

Integrated technique assessment based on the pinch analysis approach for the design of production networks. European Journal of Operational Research, Vol. 171 (3), pp. 1020-1032

Geldermann, J.; Bertsch, V.;
Rentz, O.

Nukleares Katastrophenmanagement als europäische Aufgabe – Mehrzielentscheidungsunterstützung zur Bewertung alternativer Maßnahmenstrategien. OR-News: 50 Jahre Operations Research, pp. 116-118

2.3 Book Chapters

2011

Geldermann, J.;
Wiedenmann, S.

Technique Assessment of Automotive Coating Processes Using Multi Criteria Decision Support, in: Stephanie M. Sarrica (eds.): Paints types, components and applications, Nova Science Publishers, New York, USA

2010

- Amann, K.; Uhlemair, H.; Geldermann, J. *Ausgewählte Probleme der Produktionsplanung*. In: Körner, M.-Ch., Geldermann, J., Schöbel, A.: Erträge, Diagramme und Algorithmen - Operations Research in der Praxis, Shaker, Aachen
- Geldermann, J. *Explanation Systems*. In: Rios Insua, D.; French, S.: e-Democracy: A Group Decision and Negotiation Perspective, Springer, Berlin
- Geldermann, J. *Quantifying Eco-Efficiency with Multi-Criteria Analysis*. In: Meijer, J.; der Berg, A.: Handbook of Environmental Policy, Nova Science Publishers, New York
- Lauven, L.; Geldermann, J. *Wirtschaftliches Potenzial mittels Fischer-Tropsch-Synthese hergestellter Bio-Olefine*. In: Körner, M.-Ch., Geldermann, J., Schöbel, A.: Erträge, Diagramme und Algorithmen - Operations Research in der Praxis, Shaker, Aachen
- Lauven, L.; Geldermann, J. *Logistics for Biomass-to-Liquids Plants*. In: Hiete, M., Ludwig, J., Schultmann, F. (eds.): Challenges for Sustainable Biomass Utilization, Proceedings of the Chilean-German Biociclo Workshop, 26 March 2009, KIT Scientific Publishing, Karlsruhe
- Schmehl, M.; Eigner-Thiel, S., Ibendorf, J.; Hesse, M.; Geldermann, J. *Development of an Information System for the Assessment of different Bioenergy Concepts regarding Sustainable Development*. In: Teuteberg, Marx Gómez: Corporate Environmental Management Information Systems: Advancements and Trends, IGI Global, Hershey
- Schmidtchen, T.; Schmidt, N.-H.; Kolbe, L.M.; Geldermann, J. *Der Einfluss von ökologischen Produkteigenschaften bei PCs auf die Kaufentscheidung*. In M. Schumann, L. M. Kolbe, M. H. Breitner, A. Frerichs (Hrsg.): Multikonferenz Wirtschaftsinformatik 2010, Göttingen: Univ.-Verl. Göttingen, pp. 315-326
- Lauven, L., Uskova, G. *Prospects of different feedstocks for oxo-synthesis gas generation in Bulgaria*. Машиностроене и Машинознание Jahrgang 5, Buch 2 Nummer 11, pp. 45-56, Verlag der Technischen Universität Varna

Zhang, K.; Cang, P.;
Geldermann, J.; Song, F. *Research on Innovative Information-Flow Management of E-Waste Recycling Network Based on Cloud Computing*. Chinese Control and Decision Conference (CCDC), 26.-28.05.2010, Xuzhou, pp. 1049-1053

2009

Oberschmidt, J.; Ludwig, J.;
Geldermann, J. *Ein modifizierter PROMETHEE-Ansatz zur Lebenszyklus-orientierten Bewertung der Strom- und Wärmeversorgung*. In: Geldermann, J.; Lauen, L.-P.: Einsatz von OR-Methoden zur Entscheidungsunterstützung, Shaker, Aachen, pp. 41-63

Eigner-Thiel, S.; Geldermann,
J. *Entscheidungsunterstützung bei der Planung eines Bioenergiedorfes*. In: Geldermann, J.; Lauen, L.-P.: Einsatz von OR-Methoden zur Entscheidungsunterstützung, Shaker, Aachen, pp. 22-40

Geldermann, J. *Entscheidungstheorie und Multikriterielle Optimierung*. In: Kurbel, K.; Becker, J.; Gronau, N.; Sinz, E.; Suhl, L. (Hrsg.): Enzyklopädie der Wirtschaftsinformatik, Oldenbourg-Wissenschaftsverlag, München

2008

Lauen, L.; Uskova-Werner, G. *Influence of Feedstock Choice on the Economics of Oxo-Synthesis Gas Generation*. *Машиностроене и Машинознание*, Jahrgang 3, Buch 1 Nummer 4, Verlag der Technischen Universität Varna

Daub, A.; Roland, F. *Ablaufplanung, Baustellenfertigung, Belastungsorientierte Auftragsfreigabe, Bereitstellungsplanung, Chargenfertigung, Computer Integrated Manufacturing, CONWIP, Durchführungsplanung, Einzelfertigung, Enterprise Resource Planning, Fertigung, Organisationstypen der Fertigungssegmentierung, Fertigungstypen, Fließbandfertigung, Fließfertigung, Fließprinzip, Fortschrittszahlenkonzept, Gruppenfertigung, KANBAN, Losgrößenplanung, Massenfertigung, MRP I und MRP II, Optimized Production Technology, Partiefertigung, Formen der Produktion, Produktionsmanagement, Produktionsplanung und steuerung, Produktionsprogrammplanung, Retrograde Terminierung, Serienfertigung, Sortenfertigung, Straßenfertigung, Verrichtungsprinzip, Werkbankfertigung, Werkstattfertigung*. In: Häberle, S. G. (Hg.) *Das neue Lexikon der Betriebswirtschaftslehre*, Oldenbourg Verlag, Wien, pp. 1 ff.

2007

- Geldermann, J.; Rentz, O. *Multi-criteria decision support for integrated technique assessment.*
In: Kropp, J., Scheffran, J. (eds.): Advanced methods for decision making and risk management in sustainability science, Nova Science Publishers, New York, pp. 257–274
- Bertsch, V., Geldermann, J.; Rentz, O *Preference Sensitivity Analyses for Multi-Attribute Decision Support.*
In: Waldmann, K.-H., Stocker, U.M. (eds.): Operations Research Proceedings 2006, Springer, Heidelberg, pp. 411-416
- Daub, A. *Koordination von Fertigung und Versorgung in Logistikketten.* In: Otto, A., Obermaier, R. (eds): Logistikmanagement. Analyse, Bewertung und Gestaltung logistischer Systeme, DUV, Wiesbaden, pp. 117-140

2006

- Geldermann, J.; Ludwig, J. *Einsatz von Open Source Software für Unternehmensplanspiele.*
In: Rey, U, Lang-Koetz, C, Tuma, A (eds.): Betriebliche Umweltinformationssysteme - System- und unternehmensübergreifender Daten- und Informationsaustausch, Shaker, Aachen, pp. 99-117
- Geldermann, J.; Treitz, M.; Rentz, O. *Sensitivitätsanalysen in PROMETHEE.*
In: Tammer, C. (ed.): Entscheidungstheorie und -praxis, Shaker, Aachen
- Geldermann, J. *Umwelttechnischer Fortschritt und Innovationsmanagement in China.* In: Pfriem, R.; Antes, R.; Fichter, K.; Müller, M.; Paech, N.; Seuring, S.; Siebenhüner, B. (eds.): Innovationen für Nachhaltige Entwicklung, Deutscher Universitätsverlag, Wiesbaden
- Geldermann, J. *Implementation of the European Solvent Directive.*
In: Lens, P.N.L.; Kennes, C.; LeCloirec, P.; Deshusses, M. (eds.): Waste gas treatment for resource recovery, Chapter 5, 19 pages, Kluwer

Geldermann, J., Bertsch, V.;
Rentz, O. *Multi-Criteria Decision Support and Uncertainty Handling, Propagation and Visualisation for Emergency and Remediation Management.* In: Haasis, H.-D. , Kopfer, H., Schönberger, J. (eds.): Operations Research Proceedings 2005, Springer, Heidelberg, pp. 755-760

Geldermann, J., Treitz, M.,
Bertsch, V.; Rentz, O. *Sensitivitätsanalysen in PROMETHEE.* In: Küfer, K.-H., Rommelfanger, H., Tammer, C., Winkler, K. (eds.): Multicriteria Decision Making and Fuzzy Systems - Theory, Methods and Applications, Shaker, Aachen, pp. 59-73

2.4 Conference Papers

2010

Amann, K.; Geldermann, J. *Data Assimilation in Production Planning.* World Applied Modeling and Simulation Conference 2010, May 5-7 2010, Rio de Janeiro, Brazil, Proceedings, p. 81

Amann, K.; Geldermann, J. *Kalman Filter in Production Planning.* International Conference on Operations Research 2010, September 1-3, 2010, Munich, Germany

Lauven, L.; Geldermann, J. *Economic Modeling of Fischer-Tropsch Upgrading Facilities.* World Applied Modelling and Simulation Conference 2010, May 5-7, Rio de Janeiro, Brazil, Proceedings, p. 359

Schmehl, M.; Eigner-Thiel, S.;
Ibendorf, J.; Geldermann, J. *Sustainability Assessment of Concepts for Energetic Use of Biomass – Decision Support for Rural Areas.* International Society for Industrial Ecology - MFA-ConAccount Meeting 2010, November 7-9, 2010, Tokio, Japan

Uhlemair, H., Geldermann, J. *Optimizing the production and distribution system of bioenergy villages.* Renewable Energy Research Conference 2010, June 8-9, Trondheim, Norway

Uhlemair, H.; Körner, M.-Ch.;
Geldermann, J. *Optimization of local heat networks for bioenergy villages.* Proceedings of the Third IASTED African Conference, Power and Energy Systems, September 6-8, 2010, Botswana

Lauven, L.; Geldermann, J. *Economic Modeling of Biomass-to-Liquids (BtL)-Concepts*. Renewable Energy Research Conference 2010, June 8-9, Trondheim, Norway

2009

Lauven, L.; Geldermann, J. *Application of Linear Optimization to Assess the Economic Viability of Biomass-to-Liquids Concepts*. Workshop der GOR-Arbeitsgruppen "OR im Umweltschutz" & "Entscheidungstheorie und Praxis", March 11-13, Göttingen, Germany

2008

Geldermann, J. *Multikriterielle Entscheidungsunterstützung für Automatisierungsprojekte. Effiziente Planung und Entwicklung von Automatisierungslösungen*. Fraunhofer IPA Workshop, Stuttgart, 13

Geldermann, J.; Joas, R. *Chemical Leasing as a model for sustainable development*. 19th International Congress of Chemical and Process Engineering (PRES), August 24-27, Prague, Czech Republic

Lauven, L.; Geldermann, J. *Influence of Feedstock Choice on the Economics of Oxo-Synthesis Gas Generation*. 19th International Congress of Chemical and Process Engineering (PRES), August 24-27, Prague, Czech Republic

Uhlemair, H.; Geldermann, J. *Bioenergie - Entscheidungsmodell und Unsicherheiten*. OR 2008, September 3-5, Augsburg, Germany

Petermann, J.; Geldermann, J.; Bloech, J. *Unternehmensplanspiel ComPAQ (Computersimulation Produktion, Absatz und Qualität)*. OR 2008, September 3-5, Augsburg, Germany

Schmehl, M.; Geldermann, J. *Techno-Economic Assessment of Industrial and Energy Crops*. Poster Presentation, 5th SETAC World Congress, August 3-7, Sydney, Australia

2007

- Geldermann, J.; Ludwig, J. *Process Integration for Sustainable Production Planning in an Agricultural Cooperative*. ISIE Conference 2007 (International Society of Industrial Ecology), June 17-20, Toronto, Canada
- Geldermann, J. *Techno-economic assessment of regional biomass use*. 18th International Congress of Chemical and Process Engineering (PRES), June 24-27, Ischia, Italy
- Uhlemair, H.; Geldermann, J. *Production Planning by Pinch Analysis in Dynamic and Seasonal Markets*. 18th International Congress of Chemical and Process Engineering (PRES), June 24-27, Ischia, Italy
- Schmehl, M.; Müssig, J.; Schönfeld, U.; von Buttlar, H.-B. *LCA on a Bus Body Component Based on Biomaterials*. 3rd International Conference on Life Cycle Management, August 27-29, Zurich, Switzerland
- Geldermann, J. *Multikriterielle Entscheidungsunterstützung für Automatisierungsprojekte*. In: Westkämper, E., Verl, A. (eds.): *Effiziente Planung und Entwicklung von Automatisierungslösungen / Tagungsband Fraunhofer IPA Workshop*
- Merz, M.; Geldermann, J.; Bertsch, V.; Lämpke, D.; Rentz, O. *Decision Support For Crisis Management by Large Scale Exercises*. Proceedings of the 14th Annual Conference of the International Emergency Management Society (TIEMS) Vol. 14, pp. 147-157
- Geldermann, J.; Ludwig, J.; Treitz, M.; Rentz, O. *Production Planning By Pinch Analysis For Biomass Use In Dynamic And Seasonal Markets*. 18th International Congress of Chemical and Process Engineering (PRES), June 24-27, Ischia, Italy
- Geldermann, J.; Ludwig, J.; Treitz, M.; Rentz, O. *Production Planning By Pinch Analysis For Biomass Use In Dynamic And Seasonal Markets*. 19th International Conference on Production Research (ICPR), Valparaiso, Chile
- Ludwig, J.; Treitz, M.; Geldermann, J.; Rentz, O. *Production Planning By Pinch Analysis For Biomass Use In Dynamic And Seasonal Markets*. 15th European Biomass Conference & Exhibition - From Research to Market Deployment, May 7-11, Berlin, Germany

2006

Geldermann, J.; Treitz, M.;
Schollenberger, H.; Rentz, O. *Multi Objective Pinch Analysis (MOPA) for Production Networks.*
Proceedings of the 17th International Congress of Chemical and
Process Engineering (PRES), August 27-31; Prague, Czech Republic

Ludwig, J.; Geldermann, J.;
Treitz, M.; Rentz, O. *Resource Optimization of Industry Parks: Case Studies from Chile,*
13th Latin-Iberoamerican Operations Research Conference,
Montevideo, Uruguay

2.5 Research Report

2010

- Geldermann, J.; Daub, A.,
Schmehl, M.; Hesse, M. *Chemikalienleasing als Modell zur nachhaltigen Entwicklung mit Prüfprozeduren und Qualitätskriterien anhand von Pilotprojekten in Deutschland*, FKZ 3707 67 407, Kapitel 3.1, 3.2, 3.4, 6.8, erstellt im Auftrag des Umweltbundesamtes, Dessau-Roßlau
- Geldermann, J.; Schenk-
Mathes, H.; Amann, K.,
Federowski, A.; Köster, Ch.;
Lauen, L.-P.; Lindemann, U.;
Pithan, D.; Schmidt, M.;
Springmann, J.-P. *Niedersächsische CO₂-Vermeidungspotenziale und Vermeidungskosten*. Erstellt vom Energie-Forschungszentrum Niedersachsen im Auftrag des Niedersächsischen Ministeriums für Umwelt und Klimaschutz, Goslar
- Lauen, L.; Wiedenmann, S.;
Geldermann, J. *Lebenszykluskosten als Entscheidungshilfe beim Erwerb von Werkzeugmaschinen*, Research Paper der Georg-August-Universität Göttingen, Wirtschaftswissenschaftliche Fakultät, Schwerpunkt Unternehmensführung, Professur für Produktion und Logistik, Göttingen

2.6 Publications without Review-Process

2010

- Geldermann, J.; Hesse, M.;
Joas, R.; Raab, C. *Wenn weniger mehr ist. Chemikalienleasing als Modell zur nachhaltigen Entwicklung*. Chemie & more, Vol. 3.10, pp. 18-21
- Lauen, L. *Life Cycle Costing für Werkzeugmaschinen*. Produktion - Die Wirtschaftszeitung für die deutsche Industrie, Vol. 29-30, pp.15
- Lauen, L.; Wiedenmann, S.;
Geldermann, J. *Lebenszykluskosten als Entscheidungshilfe beim Erwerb von Werkzeugmaschinen*. Research Paper der Georg-August-Universität Göttingen, Wirtschaftswissenschaftliche Fakultät, Schwerpunkt Unternehmensführung

2009

Geldermann, J.; Daub, A.;
Hesse, M.

Chemical Leasing as a model for sustainable development. Research Paper der Georg-August-Universität Göttingen, Wirtschaftswissenschaftliche Fakultät, Schwerpunkt Unternehmensführung

2008

Geldermann, J.; Bertsch, V.;
Gering, F.

Risikomanagement und Mehrzielentscheidungsunterstützung unter Unsicherheit am Beispiel der Planung effizienter Notfallmaßnahmen nach kerntechnischen Störfällen. Research Paper der Georg-August-Universität Göttingen, Wirtschaftswissenschaftliche Fakultät, Schwerpunkt Unternehmensführung

3 Research Projects

The focus of our research activities is the cost-effective and ecology-oriented design of production and logistics systems. In addition, measures for the prevention, reduction and recycling of waste materials and waste products, as well as waste disposal, are analyzed at the organizational and industry levels. We develop material- and energy-flow models to depict production systems along selected value-creation chains. These models contribute to improving resource efficiency on the business level and analyze the effects of emission-reduction processes in support of investment decisions. To integrate quantitative models and mathematical methods that support complex decision-making problems, we apply operations research methods that are associated with process engineering, production planning and multi-purpose decision-making support.

Our interdisciplinary team, consisting of ten research assistants and two PhD students, developed and executed the following research projects in the last five years:

1. Joint Research Project: “Sustainable Use of Bioenergy: Bridging Climate Protection, Nature Conservation and Society”
2. International collaboration in research and teaching between the University of Göttingen and the University of Concepción (Chile): “Sustainable Use of Energy -Generated Biomass between the Contradictory Contexts of Climate, Landscape and Society”
3. Costs and Potentials of Greenhouse Gas Abatement in Lower Saxony
4. Accompanying Economic Research for “e-Home”
5. Life-cycle Assessment of Biogas Plants in Consideration of the Regional Context in Lower Saxony (Germany)
6. PhD Program “Biodiversity and Society”: Development of Indicators to Assess the Potential Impact of Road Transport on Biodiversity
7. Collaboration and scientific exchange: “Optimization and its Applications in Learning and Industry”
8. Leasing of Chemicals as a Model for Sustainable Development with Test Procedures and Quality Criteria on the Basis of Pilot Projects in Germany
9. Analysis of Life-Cycle-Cost Business Models
10. Research Training Group (RTG 1703) “Resource Efficiency in Corporate Networks—Methods for Enterprise and Corporate-Level Planning to Utilize Renewable Resources”
11. IT-for-Green: Next-Generation Environmental Management Information Systems
12. Socio-Economic Analysis (SEA) for the Registration and Restriction according to REACH: Assessment of the Abatement Costs of Chemicals— ex ante und ex post

3.1 Joint Research Project: “Sustainable Use of Bioenergy: Bridging Climate Protection, Nature Conservation and Society”

Sponsorship: Ministry of Science and Culture of Lower Saxony; VolkswagenStiftung, 2009 - 2012, 2nd project phase: 2012 - 2013

Coordination: Prof. Dr. Hans Ruppert, Interdisciplinary Center for Sustainable Development (IZNE) at the University of Göttingen

The overall objective is the consolidation and validation of fundamental and applied knowledge for the sustainable use of energy generated by biomass. The research association consists of six sub-projects. These sub-projects pursue specific project-related objectives and interdigitate to generate new perspectives (compare Figure 1).

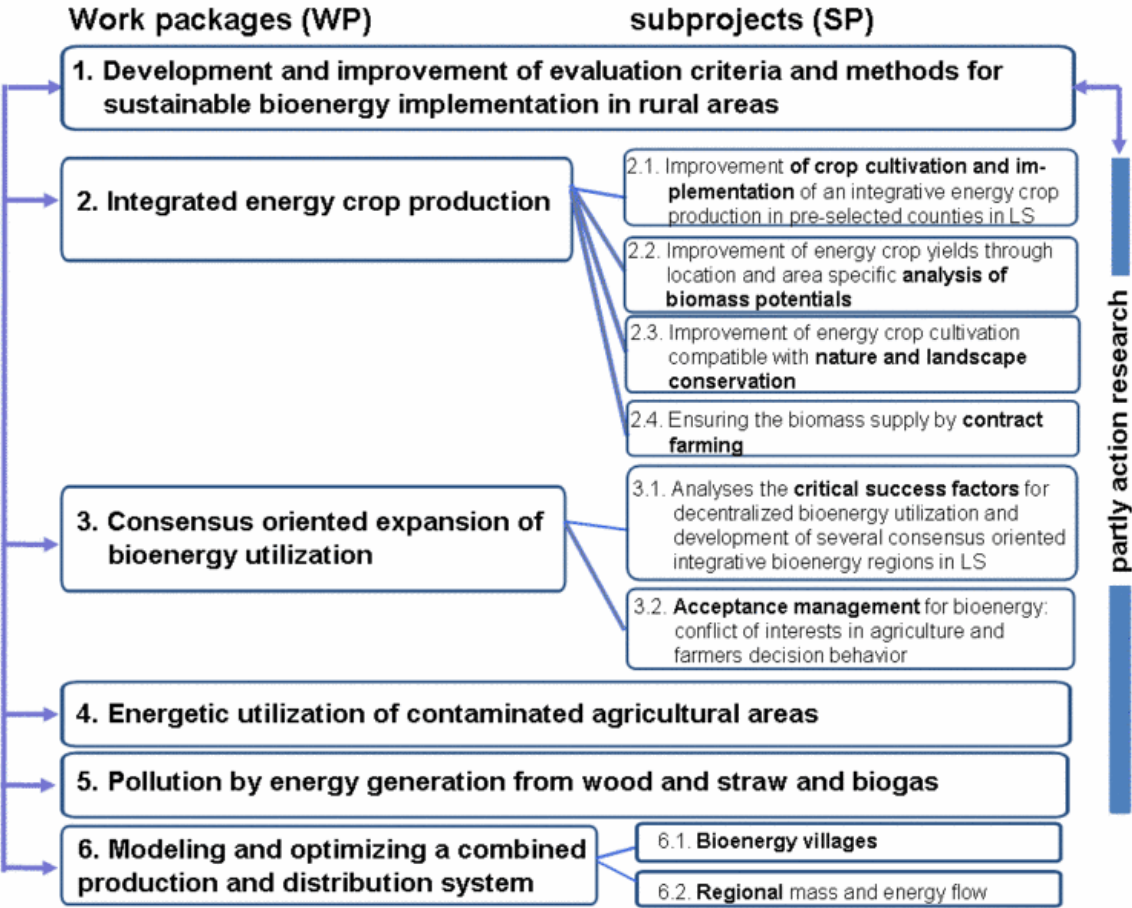

Figure 1: Sub-project of the research network “Sustainable use of bioenergy“

Sub-project 1: Development and Validation of Evaluation Criteria and Methods for Sustainable Bioenergy Implementation in Rural Areas

Beyond economic parameters, indicators should be developed to represent all three dimensions of sustainable development (economic, ecological and social factors). The development of indicator systems is complex; possible indicators may not be sufficiently specific or extensive to represent and evaluate the sustainability of local development. This sub-project focuses on the development and validation of evaluation criteria regarding the use and allocation of biomass as a renewable energy source. Significant and quantifiable criteria are elaborated in coordination with the other sub-projects.

The objective of this sub-project is to evaluate different approaches to using biomass energetically and to provide decision support for the selection of biomass usage. These approaches consider various aspects of sustainable development from ecological, economic, technical and social science perspectives. For this purpose, appropriate criteria are established, and existing sustainable indicator systems for the usage of biomass are complemented. The different concepts of biomass usage should refer to one specific region or a potential bioenergy village in Lower Saxony. For this predetermined area,

- different concepts for a bio-energy village should be compared with respect to their impact on sustainable development, and
- the impact of the cultivation of biomass on sustainable development or on other energy concepts should be examined.

The project's objective is to utilize the area requiring the least energy and technical effort in a sustainable way and to determine the most sustainable alternative. By means of multi-criteria decision analysis, the advantages and disadvantages for different concepts of biomass usage are illustrated and graphically depicted. Recommendations for the selection of certain concepts have been published.

Publications:

Eigner-Thiel, S.; Geldermann, J.:

Entscheidungsunterstützung bei der Planung eines Bioenergiedorfes. In: Geldermann, Lauven, (Eds.): Einsatz von OR-Methoden zur Entscheidungsunterstützung, Shaker, Aachen, pp. 22-40 (2009)

Schmehl, M.; Eigner-Thiel, S.; Hesse, M.; Ibendorf, J.; Geldermann, J.:

Development of an Information System for the Assessment of different Bioenergy Concepts regarding Sustainable Development. In: Teuteberg, Marx Gómez (Eds.): Corporate Environmental Management Information Systems: Advancements and Trends, IGI Global, Hershey, pp. 318-336 (2010)

Schmehl, M.; Eigner-Thiel, S., Ibendorf, J.; Geldermann, J.:

Sustainability Assessment of Concepts for Energetic Use of Biomass – Decision Support for Rural Area. International Society for Industrial Ecology - MFA-ConAccount Meeting 2010, November 7-9, Tokio, Japan (2010)

Oberschmidt, J.; Geldermann, J.; Ludwig, J.; Schmehl, M.:

Modified PROMETHEE approach to assessing energy technologies. In: International Journal of Energy Sector Management Vol. 4 (2), pp. 183 - 212 (2010)

Eigner-Thiel, S., Schmehl, M., Ibendorf, J., Geldermann, J.:

Assessment of different bioenergy concepts regarding sustainable Development. In: Ruppert, Kappas (Eds.): Sustainable Bioenergy Production – An Integrated Approach, Springer, Berlin, (in preparation, 2012)

Eigner-Thiel, S., Geldermann, J., Schmehl, M.:

Soziale Kriterien zur Bewertung der Nachhaltigkeit unterschiedlicher Biomassepfade. In: Böttcher (Ed.): Biogas, Springer, Berlin, (in preparation, 2012)

Sub-project 6: Modeling and Optimizing a Combined Production and Distribution Systems

For bioenergy villages, efficient and economically advantageous designs of individual system components have been identified. These include the components for power production (e.g., biogas, combined heat and power) and heat supply and distribution (e.g., wood chip heating plant, district heating network). The aim of this project is to develop an optimized production and distribution model that can be adjusted based on site-specific input data. With respect to economic criteria, the best system configuration and design, as well as the optimal amount of biomass use, are determined. Further sensitivity analyses are an important part of the modeling. Figure 2 shows the main components of the production and distribution system for bioenergy villages.

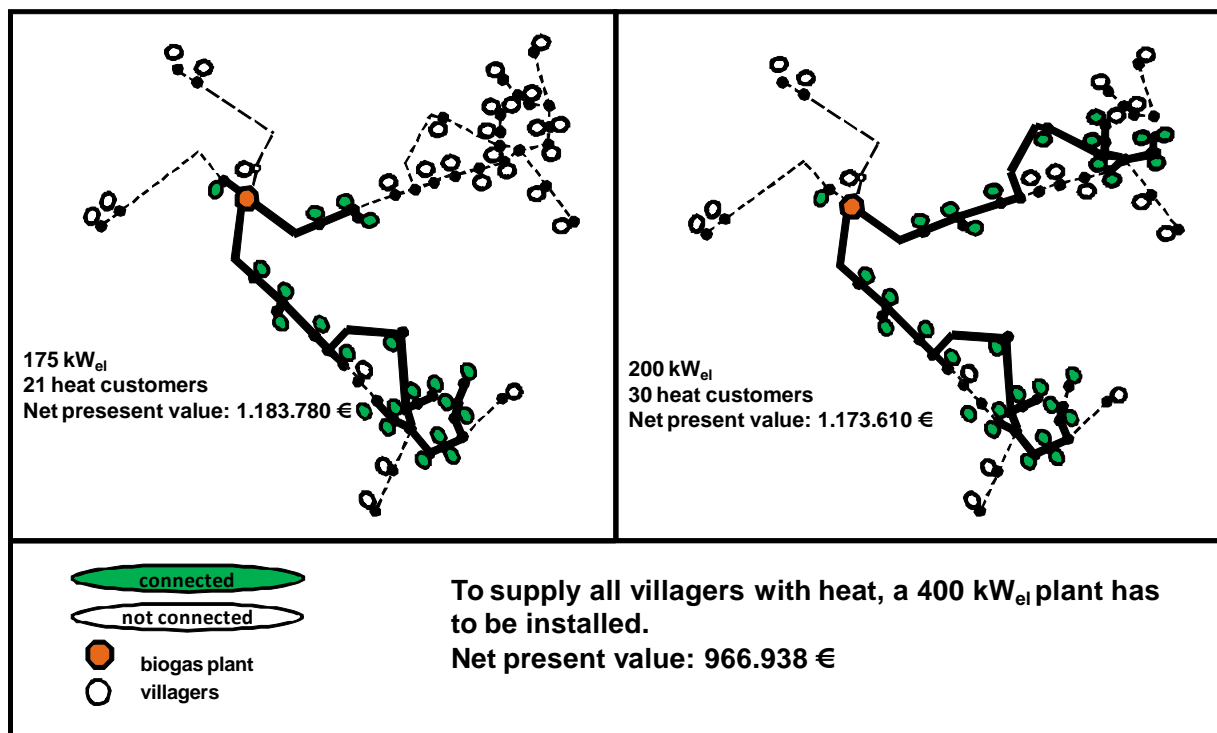

Figure 2: Production and distribution systems of a bioenergy village

Due to the interdependencies, a mathematical optimization model for the simultaneous planning of these components has been developed. It is formulated as a network flow problem and identifies the connected objects, the course of the district heating network and the system design, which lead to the highest net present value. Based on post-optimal analyses, conclusions can be drawn in terms of the effect of different constraints on the course of the network or the effect of increasing costs (induced, for example, by higher costs in the procurement of biomass) on the net present value of the whole district heating system.

Publications:

Uhlemair, H.; Körner, M.-Ch.; Geldermann, J.:

Optimization of local heat networks for bioenergy villages. Proceedings of the Third IASTED African Conference, Power and Energy Systems, September 6-8, Botswana (2009)

Uhlemair, H.; Geldermann, J.:

Optimizing the production and distribution system of bioenergy villages. Renewable Energy Research Conference 2010, June 8-9, Trondheim, Norway (2010)

Uhlemair, H.; Geldermann, J.:

Optimizing the production and distribution system of bioenergy villages. Proceedings of the 21st International Conference on Production Research (ICPR21), July 31-August 4, Stuttgart, Germany (2011)

Daub, A.; Uhlemair, H.; Ruwisch, V.; Geldermann, J.:

Optimizing the local heat distribution network for bioenergy villages. In: Ruppert, Kappas (Eds.): Sustainable Bioenergy Production – An Integrated Approach, Springer, Berlin, (in preparation, 2012)

Uhlemair, H.; Karschin, I.; Geldermann, J.:

Optimizing the production and distribution system of bioenergy villages. International Journal of Production Economics (submitted, 2011)

3.2 International Collaboration in Research and Teaching between the University of Göttingen and the University of Concepción (Chile): “Sustainable Use of Energy-Generated Biomass between the Contradictory Contexts of Climate, Landscape and Society”

Sponsorship: Federal Ministry of Education and Research, CONYCIT (Chile) (2009-2011)

The aim of the international cooperation between the Unidad de Desarrollo Tecnológico (UDT) and the Centro de Ciencias Ambientales (EULA), both at the Universidad de Concepción, and the Chair of Production and Logistics at Georg-August-University Göttingen is the exchange of experiences in the comprehensive evaluation of a sustainable regional use of biomass energy. In the context of climate change, the scarcity of fossil fuel resources and the problems in the agricultural sector, both Chile and Germany require ecologically and economically beneficial concepts that support energy supplies. Because biomass is seen as an important future energy source for both heat and electricity, the opportunities for regional biomass-utilization concepts are examined in this joint research project. Different design proposals are developed by comparing the relevant experiences of the two countries, enabling closer cooperation and a technological transfer between Chile and Germany.



Figure 3: Visit of the biogas plant in Negrete

Presentations:

Schmehl, M.:

Bioenergy Villages in Germany. Presentation at the PhD Seminar “Programa de Doctorado en Ciencias Ambientales con mención en Sistemas Acuáticos Continentales”, January 2010, Universidad de Concepción, Chile (2010)

Geldermann, J.:

Calefacción Distrital y Pueblos Bioenergéticos. Programa Seminario “Calefacción Distrital, Avances y Aplicaciones en Chile”, Gobierno de Chile, Ministerio de Energía, Ministerio del Medio Ambiente, Universidad de Concepción, Concepción et Talcuana, Chile, November (2011)

3.3 Costs and Potentials of Greenhouse Gas Abatement in Lower Saxony

Sponsorship: Ministry for Environment and Climate Protection and Ministry of Science and Culture, Lower Saxony (2009 - 2010)

Coordination: Energy Research Centre of Lower Saxony (EFZN)

Climate change poses a significant challenge for both present and future generations. In order to contain its predicted negative consequences, changes are required in almost all aspects of everyday life. According to the principle “think global, act local”, regional approaches are necessary in addition to global ones. Goals on supranational, international and regional levels need to be broken down into regional action.

In 2008, Lower Saxony has become the first federal state in Germany to constitute a government commission for climate protection. The commission supports the federal state government in developing a concept for climate protection in the federal state. Previously, the Ministry for Environment and Climate Protection of Lower Saxony (Hanover) had assigned the Energy Research Center of Lower Saxony (Energie-Forschungszentrum Niedersachsen / EFZN) to conduct a study on CO₂-reduction potentials and their related costs based on studies from the Federation of the German Industry (Bundesverband der Deutschen Industrie / BDI) and the Fraunhofer Institute for Systems and Innovation Research. As these studies reported on Germany as a whole, the CO₂-reduction potentials and the CO₂-reduction costs for Lower Saxony had to be derived. The conclusion of the study for Lower Saxony allows the identification of measures for climate protection policy. Additionally, the study resulted in recommended procedures the government can implement to reduce greenhouse gas emissions.

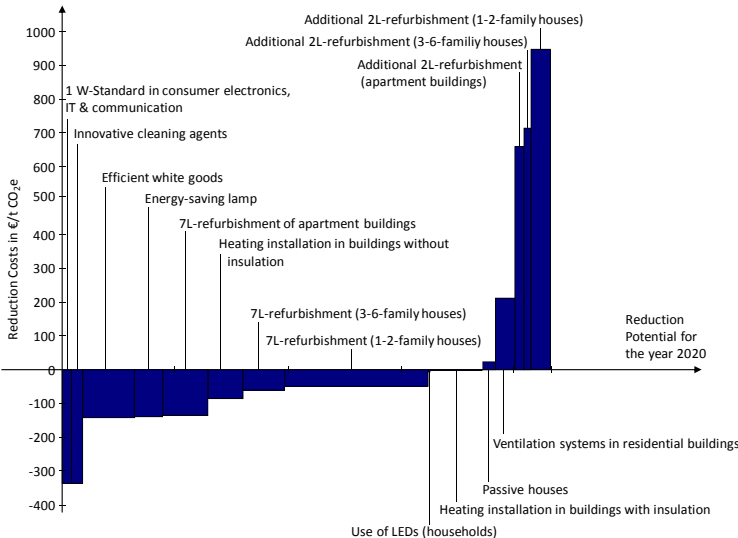

Figure 4: Costs and potentials of selected greenhouse gas abatement measures in Lower Saxony in 2020 (according to McKinsey 2007)

The study was presented on December 21st 2009, by Hans-Heinrich Sander, Minister for Environment of Lower Saxony, and Prof. Dr. Jutta Geldermann at a press breakfast. In the accompanying press release, Sander stated that the study suggested practical and region-specific action items for Lower Saxony. In addition, Sander stated that in this study, specific CO₂-abatement actions were identified for the first time. These findings may suggest low-cost measures for a state-wide climate protection program.

Publication:

Geldermann, J., Schenk-Mathes, H., Amann, K., Federowski, A., Köster, Ch., Lauven, L.-P., Lindemann, U., Pithan, D., Schmidt, M., Springmann, J.-P.:

Niedersächsische CO₂-Vermeidungspotenziale und Vermeidungskosten. Energy Research Centre of Lower Saxony (EFZN), Goslar (2010)

3.4 Accompanying Economic Research for “e-Home”

Sponsorship: E.ON Avacon AG and Energy Research Center of Lower Saxony, 2010 - 2012

Coordination: Prof. Dr. Lutz Hofmann, Institute of Electric Power Systems, Leibniz University of Hannover

In cooperation with the Energy Research Center of Lower Saxony (EFZN), E.ON Avacon AG initiated a project entitled “e-Home Energy Project 2020” (<http://www.ehomeprojekt.de>) in 2010. The project’s aim is to investigate the evolving requirements of the German electricity supply networks, which arise from projected developments in power generation and power consumption. For example, supplying the power grid with renewable energy exposes the limitations of the existing centralized power-grid network structure and thus requires investment in the extension or modification of the power grid.

This interdisciplinary project investigates the effects of different components, such as smart meters or air conditioning systems that are installed in selected detached houses, on low-voltage systems. In addition, every household may use an electric vehicle. Aside from these components, the project addresses the development of an “intelligent” local network station for low-voltage systems. This cross-sectional research project analyzes the effects in relation to technical, economic, judicial and socio-political questions. The Chair of Production and Logistics develops the economic implications of this project.

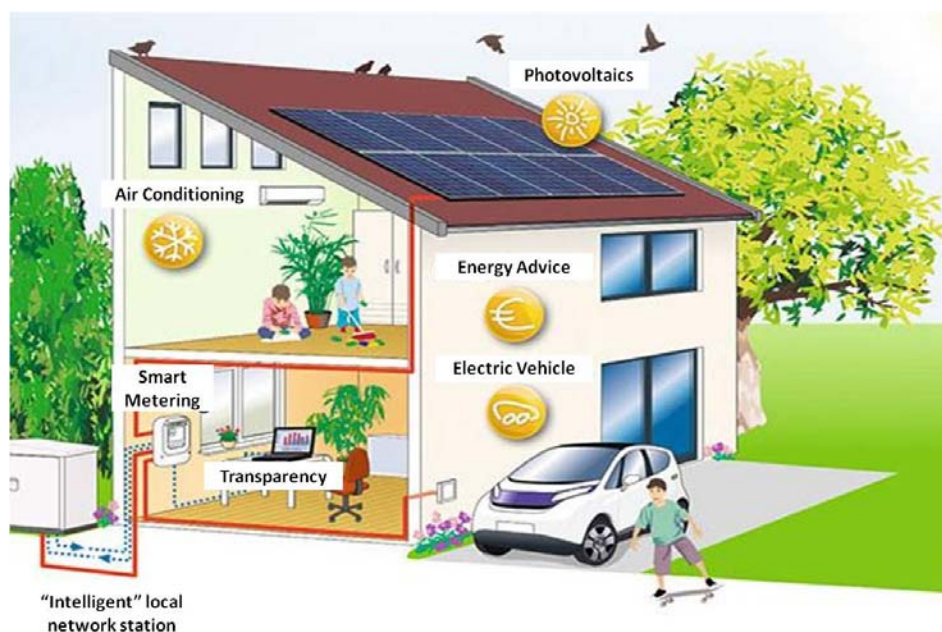

Figure 5: Model house with considered components (Source: <http://www.ehomeprojekt.de>)

3.5 Life-Cycle Assessment of Biogas Plants in Consideration of the Regional Context in Lower Saxony (Germany)

Sponsorship: Niedersächsisches Ministerium für Ernährung, Landwirtschaft, Verbraucherschutz und Landesentwicklung (Lower Saxonian Ministry of Food, Agriculture, Consumer Protection and Rural Development), Hannover, 2010 – 2011

Biogas technologies are gaining prominence in the federal state of Lower Saxony (Germany). The number of biogas plants has nearly tripled within the last seven years, from 435 plants in 2004 to 1,300 in 2011. Economic incentives for this development are provided under the Renewable Energy Law (German: EEG). Several motivations underlie this government aid: the nearly closed CO₂-cycle, the renewability of the energy sources and the stabilization of regional value-added chains.

In the context of biogas plants, however, not all effects are positive. There are also concerns that the use of monocultures will increase due to a higher demand for energy crops, resulting in massive land-use changes to accommodate more productive crops, such as maize. The designation of areas for energy crop production is a highly controversial issue as well. In cases where areas for food production, nature conservation or grasslands are used for the production of energy crops, criticism is to be expected with respect to ethics and the environment (e.g., more carbon dioxide emissions through the ploughing of grasslands and a reduction in the area’s biodiversity).

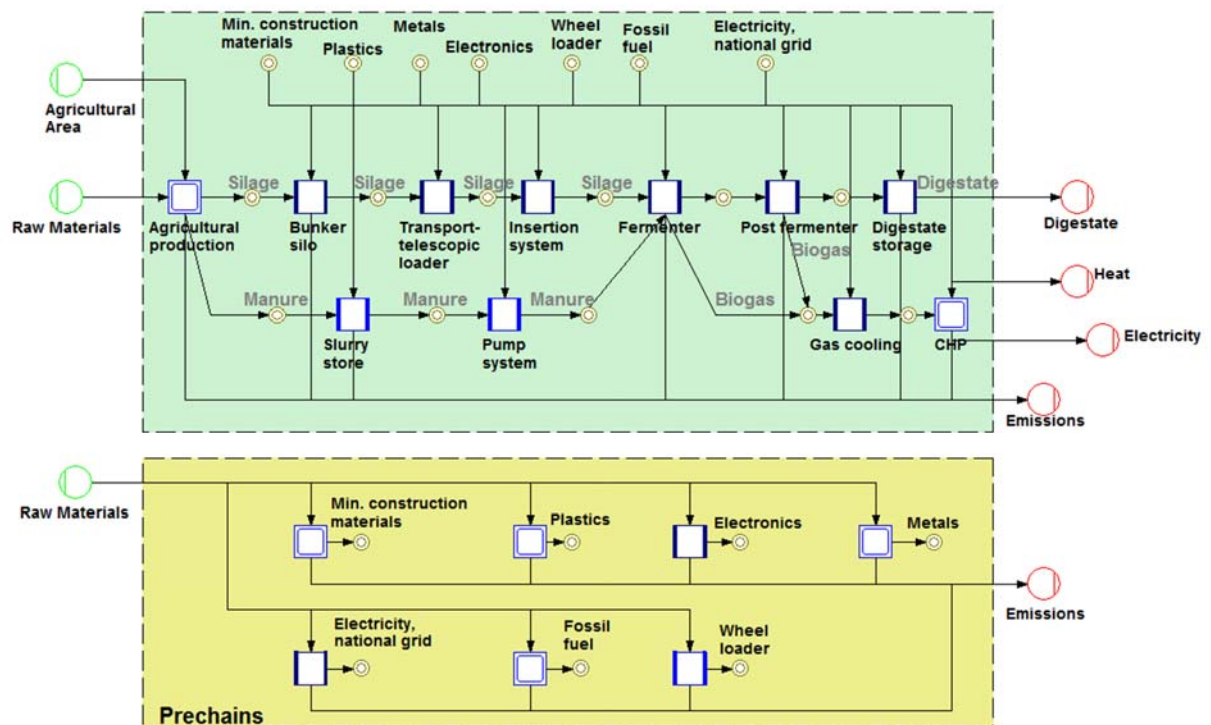

Figure 6: Screenshot of a biogas production system in the LCA software tool Umberto® 5.5

The federal state of Lower Saxony stretches from the North Sea coast to the highlands of the Harz Mountains (up to 1,000 m above sea level) and contains a wide variety of landscapes. In this study, the potential environmental impacts of individual biogas plants on five specific agricultural regions of

the federal state of Lower Saxony are analyzed according to life-cycle assessment (LCA). These include the field-crop region in the fertile plains of the south lower Saxony, the granivore region in the north-west of Lower Saxony, the grazing livestock region in the north of Lower Saxony, the field-crop region in the Luneburg Heath and the mixed region with field crop and grazing livestock.

In an LCA, the environmental aspects and potential impacts during a product's life cycle are addressed, whereby raw-material acquisition, transport, production, use, end-of-life treatment, recycling and disposal are included in the analysis.

Because generalized data sets do not allow for region-specific conclusions, such as the potential for carbon dioxide reduction, site-specific data like crop rotation, harvest yields and a kind of substrate for the fermentation process, are included in the LCA to the extent possible.

The aim of this study is to understand the region-specific ecological benefits and optimization potential of biogas plants.

Poster Presentations:

Schmehl, M., Hesse, M. und Geldermann, J. :

Durchführung einer ökobilanziellen Bewertung von Biogasanlagen unter Berücksichtigung der niedersächsischen Verhältnisse. In: KTBL (Ed.): Biogas in der Landwirtschaft – Stand und Perspektiven, Proceedings of the FNR/KTBL-Congress, September 20-21, Göttingen, Germany (2011)

Schmehl, M., Hesse, M. und Geldermann, J.:

Lifecycle Assessment of Biogas Plants in Consideration of Regional Specifics within Lower Saxony (Germany). In: Faulstich (Ed.): From research to industry and markets, Proceedings of the 19th European Biomass Conference and Exhibition, June 6-10, Berlin, Germany (2011)

3.6 PhD Program “Biodiversity and Society”: Development of Indicators to Assess the Potential Impact of Road Transport on Biodiversity

Sponsorship: Ministry of Science and Culture of Lower Saxony; VolkswagenStiftung,
2009 - 2012, 2nd project phase: 2012 - 2013

In 1992 and 1993, 168 states ratified the Convention on Biological Diversity. In doing so, they affirmed that “the states are responsible for conserving their biological diversity and for using their biological resources in a sustainable manner.” Although this convention reflects a political consensus, 20 years later, the rate of loss of biological diversity continues to increase. However, these figures can be understood as the result of a recent increase in monitoring; after failing to fulfill the 2010 targets, more concrete and better-monitored national strategic plans have increasingly been implemented. Furthermore, in the IPBES, an international scientific organization was founded to analyze the 2005 Millennium Assessment results regarding the degrading condition of ecosystems and the extinction or elevated risk of extinction of their native species. In addition to reporting on natural sciences, the organization included other factors to persuade humankind to take a new approach in its relationship with the natural world. Among those factors are a rise in environmental awareness, which translates into altered consumer demands; an understanding of a macro-economically inefficient usage of ecological resources as disclosed in the Stern Review or in the TEEB Study; and the appearance of ethically unjust causes and effects, which become evident in the phenomenon of climate change, for example. These indications suggest that businesses in the future will be motivated to develop and produce products that have limited negative environmental effects. To achieve this aim, these effects must be identified and managed. The area of research on biodiversity and transport aims to make advances in both of these endeavors.

Many effects of business processes on ecology have been considered within the rubric of life-cycle assessment in recent years. The resulting knowledge has resulted in software programs and allows for the better management of individual effects. However, the focus thus far has been on pollutants and CO₂-equivalent emissions because the pollution levels in ecosystems and the causes of climate change are now known. Currently, the world is faced with a new ecological phenomenon, the loss of biodiversity. Such a loss places humans’ benefit from the earth’s ecosystems in jeopardy.

One area of environmental impact that has not yet been fully understood concerns the effects of transport. At the business level, missing pricing signals, insufficient awareness, and missing management tools appear to be the main causes of this type of environmental impact. The research conducted in this area addresses the missing management tools. This project aims to generate a management tool that will allow for a more comprehensive understanding of the ecological effects of road transportation and that facilitates their measurement. While greenhouse gas emissions, invading alien species, and road mortality are important

disadvantages, the effects of land use and fragmentation are explicitly analyzed in this project. These two effects were selected because no form of corporate measurement yet exists for either, and because the fragmentation effect among natural science researchers is viewed to be “one of the most significant negative impacts of human activities on living nature.” This assertion speaks for the importance of transportation’s consideration within the rubric of sustainable development.

Although the problem primarily concerns spatial planning, its scope, along with the variable of other drivers’ road usage, makes it a relevant issue for the sustainability agenda of businesses, as well. Although inland navigation and rail transport are preferable to road transport for reasons of emissions and land-use intensity from an ecological viewpoint, elevated shipping volumes promote land use and increase fragmentation pressures. Therefore, one approach entails first bundling transportation infrastructure and second, providing for the costly permeability of the infrastructure, through overpasses or wildlife crossings, for example. An individual company that wishes to reduce its transportation footprint then has the opportunity to predominantly use traffic-aggregated and permeable infrastructure, as well as to develop business models that require lesser transportation volumes.

Publications:

Friedrich, J.; Geldermann, J.:
Integrating Additional Ecological Impacts from Road Transport in Business Decision-making. In: Proceedings of the 1st World Sustain, Forum, Sciforum Electronic Conferences Series, 1-30 November, (2011)

3.7 Collaboration and Scientific Exchange: “Optimization and its Applications in Learning and Industry“

Sponsorship: EU, International Research Staff Exchange Scheme (IRSES), 2010 - 2014

Coordination: Prof. Dr. Anita Schöbel, Institute for Numerical and Applied Mathematics - Research Group Optimization

Project partners: Technical University of Kaiserslautern, Technical University of Denmark, University of Auckland (NZ), University of Canterbury (NZ)

Since December 2010, the collaborating universities of Kaiserslautern, Denmark, Auckland and Canterbury, located in Europe and New Zealand, have participated in the project, “Optimization and its Applications in Learning and Industry (OptALI; <http://optali.com>).” The OptALI project encourages the exchange and strengthening of research collaboration via an exchange program that allows European OptALI members to visit Auckland and Canterbury Universities and New Zealanders to visit the European partner universities. Other activities include workshops in both New Zealand and Europe.



Figure 7: The OptAli Team of Researchers

The Chair of Production and Logistics is involved in the following tasks:

Task 1.1: Identification and collection of challenging research topics related to industrial applications. Each of the subjects is collected on the project’s webpage, such that the tasks we identified in pushing the theory towards practice become visible. In particular, interested students may apply to work on one of the subjects in the context of a PhD thesis and to join the project as early-stage researchers.

Task 2.2: Lectures on Multi-criteria Optimization.

In real-world problems, it is often necessary to consider conflicting objectives, e.g., economic versus social or environmental criteria, when making decisions. Hence, multi-criteria optimization is an essential technique when trying to optimize in practice. In these lectures, we present the latest findings in multi-criteria optimization analysis, focusing on those techniques that are applicable within our industrial projects.

Task 3.3: Raising new Applications for Optimization.

In this task, we seek active industry involvement. We will present results from existing industrial collaborations and work completed within the program during two workshops to demonstrate the impact of optimization in practice. We solicit input from industry in the form of presentations and discussion sessions to identify new challenges for the future. This task will form the basis for ongoing collaboration at the completion of the project.

Publication:

Wiedenmann, S.:

Investigating supply planning of agricultural renewable resources to be refined for industrial production processes under consideration of varying qualities and quantities. In: During the summer course from December 1, 2010 to February 22, 2011 on Integer Programming (<http://optali.com/workshops/auckland2011/>) (2011)

3.8 Leasing of Chemicals as a Model for Sustainable Development with Test Procedures and Quality Criteria on the Basis of Pilot Projects in Germany

Sponsorship: Federal Environmental Agency (Umweltbundesamt UBA Berlin/Dessau), 2008 – 2010

Coordination: BiPRO GmbH (Munich)

Chemical leasing is an innovative business model that replaces the traditional quantity-based payment (for example, euro per ton of detergent) with a payment related to the use of chemicals (for example, euro per square meter of cleaned surface). This creates a financial incentive for the chemical manufacturer to reduce the customer's use of chemicals through process optimization. As a consequence, there is growing cooperation between chemical manufacturers and customers. This collaboration can lead to economic benefits for both partners, as well as to the reduced consumption of chemicals, the conservation of resources, reduced pollution, energy conservation and the prevention/reduction of risks from chemical usage. In this research project commissioned by the Federal Environmental Agency, the quality criteria for this model were developed on the basis of eight pilot projects. These criteria help to ensure the business model's high performance in terms of environmental and health effects. A separate working committee established to assist with the research project has discussed the identified quality criteria; the criteria are currently being tested and implemented by the United Nations Industrial Development Organization (UNIDO) on an international scale.

In addition, quality criteria were developed with regard to possible public support for chemical leasing and for the targeted communication and collaboration between the parties. Furthermore, the pilot projects were used to analyze inhibitory and promoting factors for the successful implementation of chemical leasing. Proposals were thus developed to determine appropriate communication measures and incentives to further apply the business model.

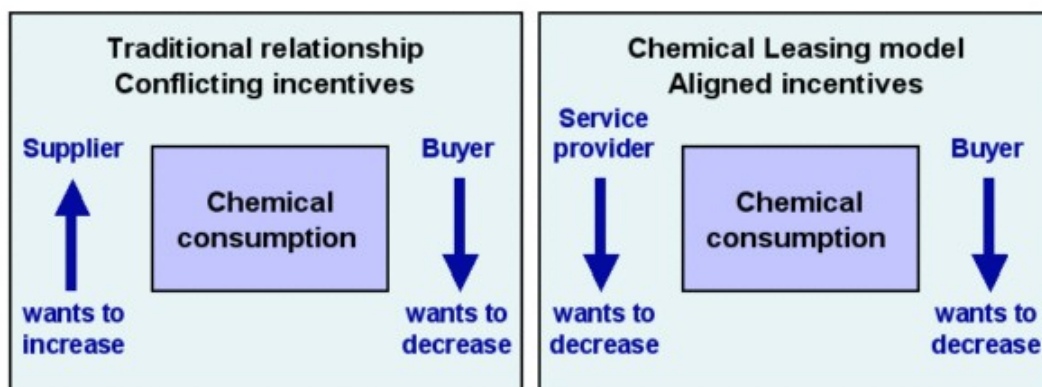

Figure 8: Concept of Chemical Leasing (<http://www.chemicalleasing.com>, UBA 2010)

Publications:

Geldermann, J.; Daub, A., Schmehl, M.; Hesse, M.:

Chemikalienleasing als Modell zur nachhaltigen Entwicklung mit Prüfprozeduren und Qualitätskriterien anhand von Pilotprojekten in Deutschland. FKZ 3707 67 407, Kapitel 3.1, 3.2, 3.4, 6.8, erstellt im Auftrag des Umweltbundesamtes, Dessau-Roßlau (2010)

Geldermann, J.; Hesse, M.; Joas, R.; Raab, C.:

Wenn weniger mehr ist. Chemikalienleasing als Modell zur nachhaltigen Entwicklung. Chemie & more, Vol. 3.10, pp. 18-21 (2010)

Geldermann, J.; Daub, A.; Hesse, M.:

Chemical Leasing as a model for sustainable development. Research Paper der Georg-August-Universität Göttingen, Wirtschaftswissenschaftliche Fakultät, Schwerpunkt Unternehmensführung (2009)

3.9 Analysis of Life-Cycle-Cost Business Models

Sponsorship: Industry project, 2009 – 2010

This German machinery firm and plant faced more difficult competition due to the drop in demand during the financial crisis. The increased competition from other countries called for a greater differentiation of products. High cost pressures, declining margins and extended product responsibility have an impact on the lifetime of complex products, machinery and equipment.

More important is the evidence resulting from the investment costs during the entire life-cycle of the procurement decision. In terms of long-term advantage, capital goods are a critical addition to procurement costs, especially in terms of maintenance, repair and unscheduled plant shutdowns. To systematically account for these cost factors in investment decisions, the life-cycle-cost concept (Life-Cycle Cost - LCC) has been developed. All of the costs that will be incurred over the product's entire life-cycle should be considered, from acquisition to disposal costs. To determine the specific design of these concepts from the perspective of machinery manufacturers, different life-cycle cost contracts are presented.

Particular emphasis is placed on incentive systems and the mechanisms that allow for the fair distribution of the associated income and expenditures. Subsequently, the opportunities and challenges are demonstrated and explained.

Publications:

Lauven, L; Wiedenmann, S.; Geldermann, J.:
Lebenszykluskosten als Entscheidungshilfe beim Erwerb von Werkzeugmaschinen. Research Paper der Georg-August-Universität Göttingen, Wirtschaftswissenschaftliche Fakultät, Schwerpunkt Unternehmensführung, Professur für Produktion und Logistik, Göttingen, Oktober (2010)

Lauven, L:
Life Cycle Costing für Werkzeugmaschinen, Produktion - Die Wirtschaftszeitung für die deutsche Industrie, Ausgabe 29-30, S. 15 (2010)

3.10 Research Training Group (RTG 1703) “Resource Efficiency in Corporate Networks - Methods for Enterprise and Corporate-Level Planning to Utilize Renewable Resources”

Sponsorship: German Research Foundation (DFG), 2012 – 2016

Coordination: Chair of Production and Logistics

From April 2012 to September 2016, the German Research Foundation (DFG) will fund the RTG 1703 with more than 4 Mio. Euro, allowing for 12 doctoral positions (75% - TVL 13). Another 12-15 doctoral students with funding from other sources will be associated with the RTG. The training group is located in the Faculty of Economic Sciences at Prof. Dr. Jutta Geldermann’s Chair of Production and Logistics.

The overall aim of the research-training group is the development and application of methods for the improvement of resource efficiency in corporate networks. It focuses on the efficient utilization of renewable resources in combined production processes with multiple outputs. The ultimate goals are the increase of resource efficiency through the use of by-products and the cascadic utilization of renewable resources through multiple sequential utilization of the same input and prior to energetic utilization. The aspiration of efficiency aims is seen as a contribution to sustainability management by changing the course of action in all areas of the network - in-plant and corporate, on operative, tactical and strategic levels, with respect to systems and processes, material suppliers, manufacturers, retailers as well as consumers. As the common starting point, lignocellulosic materials are selected. From the business administration’s perspective, lignocellulosics are suitable for manufacturing as well as for the process industry. They require appropriate planning methods. To identify economic incentives, models and methods of operations research are used for decision support. Issues requiring further research exist due to uncertainties in the quality and quantity of renewable resources, as well as in the handling of multiple, sometimes conflicting, goal functions and the requirements of data processing. Besides the requirements of single enterprises, the consequences at the corporate level must also be investigated: for example, the configuration of information management and data interchange, business relations and organizational structures. Consideration of the markets completes the analysis and allows for conclusions regarding the requirements of product design.

The common approach to this research topic of resource efficiency by the participating faculties of agricultural sciences, forestry, mathematics and economic sciences facilitates a broad understanding of current issues.

To emphasize a realistic view of the challenges of related companies and networks, doctoral students are encouraged to undertake two month-long internships. We are currently seeking interested industrial partners.

Additional information is available at www.resource-efficiency.uni-goettingen.de.

3.11 IT-for-Green: Next-Generation Environmental Management Information Systems

Sponsorship: European Commission, EFRE – European Fund for Regional Development), 2011 – 2014

Coordination: University of Oldenburg, Prof. Dr. Jorge Marx Gómez

Partners: University of Oldenburg (Prof. Dr. Wolfgang Nebel), University of Osnabrück (Prof. Dr. Frank Teuteberg), CeWe Color AG & Co. OHG, Hellmann World Wide Logistics GmbH & Co KG, iits GmbH & Co. KG, erecon AG, Community of Spiekeroog, SAP AG.

Environmental management information systems (EMIS) are a crucial element of effective and efficient environmental management because they (1) support the organization by identifying activities, products or services that have significantly negative impacts on the environment and (2) trigger measures that reduce or eliminate these negative impacts. EMIS thus helps to meet the requirements of the environmental management standard ISO 14001 and the EMAS regulations, whereby companies can benefit from several privileges. However, working with current versions of EMIS is a time-consuming task that only large companies can afford. Therefore, the IT-for-Green project's main objective is to make EMIS available for small- and medium-sized companies, developing services that meet the special needs of the target group in terms of usability, process integration, data quality, and interaction with other software.

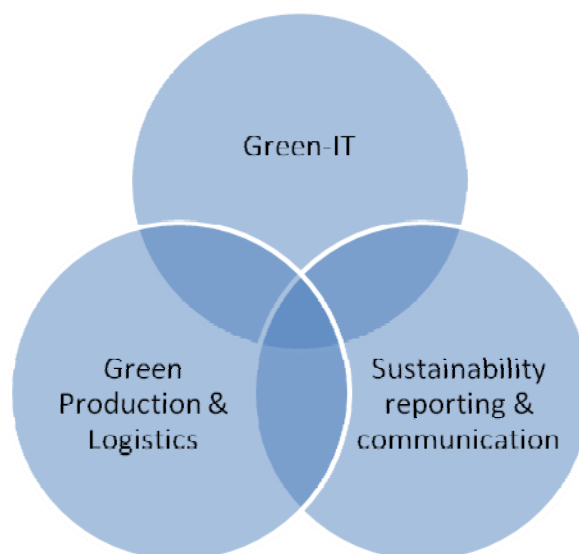

Figure 10: Core services to be developed by the IT-for-Green project

Within the IT-for-Green project, three different types of services for small- and medium-sized companies will be developed together with a lean service oriented architecture platform for orchestrating these services. The first service will facilitate quantifying the energy consumptions of data centers (“Green IT”); the second service will assist the user to quantify (1) the CO₂-emissions of a specific freight transport order via different means of transportation and (2) energy efficiency, material efficiency, water consumption, waste generation, land use, and emissions of specific production systems (“Green Production & Logistics”); and the third service will generate a report that

automatically contains all of the relevant key figures (“Sustainability reporting and communication”). The Chair of Production and Logistics is responsible for developing the second service. During the entire project, the theoretical and practical experience of the ertemis network (constituted of several universities, research institutes and companies focusing on the improvement of EMIS) is available to all members of IT-for-Green to ensure a high level of practicability with respect to the project’s final results.

3.12 Socio-Economic Analysis (SEA) for the Registration and Restriction according to REACH: Assessment of the Abatement Costs of Chemicals– ex ante und ex post

Sponsorship: Federal Environmental Agency (Umweltbundesamt UBA Berlin/Dessau) 2011 – 2013

Coordination: BiPRO GmbH (München)

Project Partner: Oeko-Institut e.V.

REACH is the European Community Regulation on chemicals and their safe use (EC 1907/2006). It deals with the registration, evaluation, authorization and restriction of chemical substances. Against the backdrop of chemicals that are subjected to risk-management measures under REACH, the need has arisen to collect, assess and validate cost data associated with the substitution of the substances or the reduction of their emissions. These cost data are necessary to facilitate decisions within the context of requests for authorization of substances listed under Annex XIV of the REACH Regulation as well as for the assessment or generation of Annex XV dossiers with a view to including substances in certain applications into Annex XVII of the REACH Regulation. Abatement costs are required wherever a full socio-economic analysis (SEA) cannot be carried out.

Certain chemicals shall be selected for which such abatement costs (i.e., the compliance costs of abating emissions of these chemicals) should be collected and calculated. The client requests assistance in establishing the capability to assess the corresponding abatement costs of these substances. For some substances, complete data are missing; hence the objective is to be met by collecting abatement-cost data.

The main objective of this project is to collect and analyze data regarding the abatement costs of chemical emissions on the basis of sample substances. In this analysis, the focus of the project will be on the costs of using alternative substances and techniques (processes and products). The contractor is expected to conduct an ex-ante analysis as well as an ex-post analysis of abatement costs by selecting suitable sample cases. The contractor shall consider and build upon the results of ongoing activities on the European level mentioned above and - as appropriate - is expected to cooperate with other contractors involved in these activities.

In the development of this project, the cost guidelines of the European Chemicals Agency (ECHA) in Helsinki are to be taken into account.

4 Doctorates

4.1 Current Doctorates

Katharina Amann:

Data Assimilation for Production Planning (since 2009)

Jan Friedrich:

Development of Indicators for the Estimation of Potential Effects of Road Transport on Biodiversity (since 2010)

Martina Hesse:

A Cascading System for Extending the Carbon Storage Effect of Wood and Derived Timber (since 2009)

Lioba Markl-Hummel:

Multi Criteria Decision Support for Communal Climate Protection Measures (since 2008)

Meike Schmehl:

Techno-economic Assessment of Renewable Resources for Energy Supply (since 2007)

Henning Gössling:

Decision Support for Emergency Management (since 2011)

Ingo Karschin:

Development of a Mass and Energy Flow Model for Bioenergy Villages with regard to multiple criteria (since 2011)

Heti Mulyati:

The Supply Chain Risk Management System Seafood Industry in Indonesia (since 2011)

Fabian Renatus:

Interactive Multi Criteria Decision Support for Environmental Management Information Systems (since 2011)

Harald Uhlemair:

Optimizing the production and distribution system of bioenergy villages (since 2007)

Genoveva Uskova:

Development of a Multi Criteria Decision Support System for Innovative Mobility Concepts (since 2009)

Ute Weissfloch:

Multi Criteria Decision Support for service oriented business models of compressed air systems (since 2009)

Susanne Wiedenmann:

Management of Uncertainties in Production Planning for Renewable Resources (since 2009)

4.2 Completed Doctorates

Julia Oberschmidt:

Multikriterielle Bewertung von Technologien zur Bereitstellung von Strom und Wärme
(Multi criteria assessment of technologies for the supply of electricity and heat)
(2010)

Sumetee Wongsak:

Development of a decision support system for logistics planning for agricultural products in Thailand)
(2011)

Lars Lauen:

Evaluation of the Economic Perspectives of the Production of Synthetic Hydrocarbons in Germany
(2011)

5 Team

Chairholder	Prof. Dr. Jutta Geldermann
Research Associates / Ph.D. candidates	Dipl.-Wi.-Ing. Katharina Amann PD Dr. Anke Daub M.Sc. Jan Friedrich Dipl.-Wirtsch.-Ing. Henning Gössling Dipl.-Forstw. Martina Hesse Dipl.-Math. Ingo Karschin Dr. Lars-Peter Lauven MT, Heti Mulyati M.Sc. Fabian Renatus Dipl.-Geoökol. Meike Schmehl Dipl.-Kfm. Harald Uhlemair Dipl.-Kffr. Genoveva Uskova Dipl.-Wi.-Ing. Susanne Wiedenmann
External Research Associates / Ph.D. candidates	Dipl.-Wi.-Ing. Lioba Markl-Hummel Dipl.-Chem.-oec. Ute Weissfloch
Office Management	Claudia Kohrell
Emeriti	Prof. em. Dr. Dr. h.c. Jürgen Bloech Prof. em. Dr. Dr. h.c. Wolfgang Lücke
Honorary Professors	Prof. Dr. Werner Frank (†2011) Prof. Dr. Wolfhard Gottschalk